

Technologies for the Introduction of Digitalized Cultural Heritage to Visually Impaired People

Neli Simeonova, Radovesta Stewart, Ekaterina Gospodinova

University “Prof. Dr. Assen Zlatarov”, Burgas, Bulgaria
neli_simeonova@btu.bg, radadeva@yahoo.com,
ekaterina_gsopodinova@abv.bg

Abstract. This paper presents the place of technologies and digitalization for the creation of an opportunity for visual impaired people to become acquainted with the cultural heritage not only as text and as sound but also images. A concept for hardware realization of graphic tactile display is outlined based on a technology using tactile actuators bi-stable, solenoids and PIC based control board. The selected algorithm for series activation of each row of display allows using minimal number of active components to set and reset the solenoids and make possible the representation of an image, described additionally through text to sound readings of an object description.

Keywords: Digital Resources, Cultural Heritage, Visually Impaired People.

1 Introduction

Providing optimal access to cultural heritage to the members of vulnerable groups is in recent years strongly encouraged by both national and European cultural policies. Museums and galleries play the role of crossroads by connecting people, regardless of their nationality, disabilities, social and economic status and beliefs. Popular thought among the cultural tourism researchers is that “heritage only has significance to the extent that it benefits people. If people are prevented from experiencing a heritage asset, it can no longer be considered part of their heritage.” (Garrod & Fyall, 2000). Every man in the world has the need to communicate with the surrounding world and be able to feel as a part of the society bound by its heritage and culture. One group of the people with disabilities is particularly disadvantaged when it comes to creating an opportunity for getting acquainted with the objects of cultural and historical heritage. This group consists of the visual impaired people. They “see” through touch but most of the museum exhibits are behind glass or not permitted for touch due to security restrictions or heavy chemical usage for their preservation. However, with the advancement of computers and the Internet the existing physical boundaries are becoming less restrictive and a new era in communication has started. Every day billions of people connect with each

other, share information, experience, emotions and ideas regardless of their body restrictions and even disabilities, even though vision is a key for the use of computer technologies.

People with reduced sight perceive the surrounding world most often by sound or by direct contact in particular, by touching objects. Touch is the most important sense for the blind and is developed through use. That is why tactile aids do not only have a cognitive function but also play a significant role in touch development and care (Valič, 2015).

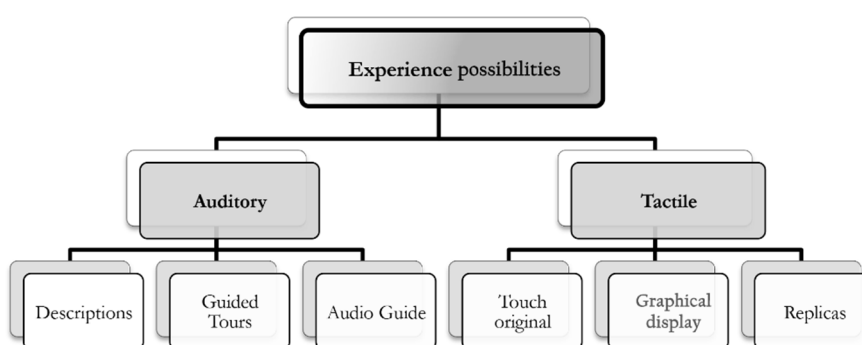

Fig. 1. Experience possibilities for visual impaired people

The experience possibilities described in Fig. 1 show the two ways of providing access to the cultural heritage for visitors with visual problems. The first one is based on the use of audio guides. However, the experience of the museum experts points out that the audio guides are not enough to satisfy the curiosity of people with such disabilities.

The second option - tactile may include Braille description, replicas of the objects, tactile cards and the suggested method in this paper – through tactile graphical displays. Acquiring information by touch is classified into two main ways – kinetic aesthetic and tactile. The first one is usually related to the sense of location, velocity and force and it is generated by contraction of muscles and tendons. The devices designed on this basis interact with the user applying computer controlled force, thus creating an illusion for continuous and stable relation to the object. (Burdea, 1996) The perception through touch is most often related to the direct contact of the skin with the surface explored which is expressed by feeling of pressure, pulling, vibration and temperature.

By traditional methods of presentation of information, the Braille alphabet is used. However, it is effective only when the information is in the form of text and is not universal as the Braille represents the alphabet of different languages. It turns out to be quite ineffective when a graphical image is to be presented. For this purpose the tactile cards have been used. They represent images printed with embossed ink on paper. They are cheap but are easily damaged. Another option is the development of replicas of the most representative museum objects. They can be created with a 3D printer after they have been digitalized and modelled.

Only one of these options offers sustainable access to the cultural heritage and makes possible the use of its digital form - tactile displays.

2 Tactile Graphical Display

The tactile displays are a complex electro-mechanic system, where each pixel is controlled individually and its activation is identified by its translation and setting at certain height. Various methods for realization of mechanical movement of individual pixels have been developed so far. Yobas et al. (Yobas, Durand, Skebe, Lisy, & Huff, 2003) used miniature electrostatic valves built on the basis of elastic thin-layer membranes of poly-silicon which expand when air pressure is applied to them and contract under electric voltage. The use of such technology reduces significantly the size of the driving mechanism. Sizes by the order of $70\mu\text{m}$ were achieved which would allow realizing tactile displays of high resolution. Nevertheless, the problems related to membrane cracking when electric voltage is applied without air pressure prevented their wide use. Interesting portable device is the diaphragm suggested by a team of Chinese researchers (Wu, Zhu, Kim, & Allen, 2007), which showed significant strength and stability under pressure but the weak point of the design turned out to be the necessity to recharge the pneumatic system with compressed air and the risk of possible injuries by accidental failure of the air pressure system.

Safer for the user are the systems where the driving is electric rather than pneumatic. More and more, piezoelectric linear microdrives are used for the positioning of the individual pixels (Cho, Kim, Park, & Song, 2006), bimetal plates (Yang, Kyung, Srinivasan, & Kwon, 2006) and alloys Shape Memory Alloy (SMA), which changes their size when electric current is passed through them and restore their previous shape when current stops. The main disadvantage of the mentioned technologies is their high technological costs. As most of the visually impaired people would not be able to afford such displays, it becomes necessary to search for alternative solutions. On the other hand, the development of micro-electromechanical systems (MEMS) allowed creating miniature solenoids which could successfully be used in a design of a tactile display which will be much more affordable for individual people at their homes as well as organizations such as museums. The displays can be connected with the systems for presentation of digitalized cultural heritage and the blind can “view” the images of the exhibits through touch.

The presented concept in short describes a hardware realization of graphical interface for visually impaired on the basis of micro two-positional systems. The use of solenoids in tactile displays is not a new idea. Some of the first prototypes were based on the same concept. Despite the simplicity, as far as construction is concerned, they are quite ineffective due to the large amount of energy consumed to initiate and maintain the active state of the solenoids. On the other hand, the design of a graphical display with two-positional solenoids will significantly reduce the energy consumption since it will be consumed only by turning the solenoids on and off while the plunger is detained by permanent magnets (Simeonov & Simeonova, 2013).

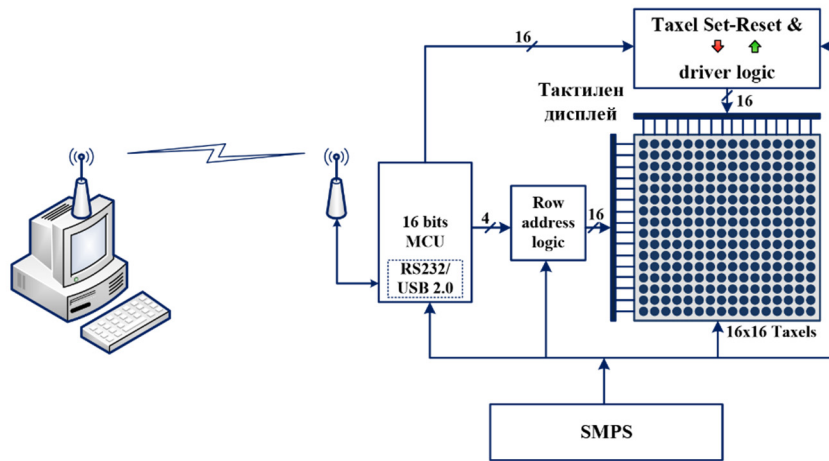

Fig. 2. Block diagram of a tactile display for visually impaired people

A block diagram of a solenoid based display with resolution 16x16 taxels (Genkov, 2011) for visually impaired people is shown in Figure 2.

The diagram includes the following main units:

- 16-bit microcontroller with integrated RS232/USB 2.0 interface;
- Logical unit for addressing display rows;
- Unit for initialization and resetting the taxels;
- Solenoid board;
- Power supply unit.

The main controlling unit of the display is a 16-bit peripheral circuit board with microcontroller PIC24FJ32GB002, product of Microchip. The microcontroller comprises hardware support for USB v2.0 standard which allows realizing the connection between the display and the user system through cable or by Wi-Fi. The choice of the 16-bit microcontroller was stipulated by the condition of simultaneous initialization and resetting the display taxels. The controller has 21 Input/Output pins which are enough for the repetitive scans of display rows simultaneously with the taxels initialization. Four of the pins at port A are used for instructions to the logical circuitry for row selection while the pins at port B are used to send signals for turning the solenoids on and off.

The PIC microcontroller is of 16-bit architecture and has 32 Kb software memory and 8 Kb RAM (Frisken-Gibson, Bach-Y-Rita, Tompkins, & J.G., 1987). Its speed reaches up to 16 MIPS and it is optimized for programming in C language. The idea of the algorithm for the microcontroller is to make the display available as soon as the power supply is switched on. On a command to bring an image to the display, the scanning of rows begins and the corresponding taxels are activated. As soon as the image is on the screen, the controller waits for the operator to give command to clear the display, which triggers new scanning of rows to bring them to the initial state and making it possible to load another image.

3 Conclusions

The present report outlines the possible usage of technologies in order to offer access to cultural heritage to people with sight problems. A concept for hardware realization of a graphical tactile display for visually impaired people based on two-positioned solenoids with consecutive activation and deactivation of display taxels was suggested and substantiated. The implementation of this technology requires the digitalization of cultural heritage. At least the representative exhibits should be digitalized and made tactilely accessible. The preparation of tactile aids should consider the features of the museum object and cognitive abilities of the blind visitors. A thorough description is also required which to accompany the tactile representation of the object. The aim is to explore the potential of digital space and technologies to improve access to cultural heritage research and knowledge of specific cultural valuables preserved in museum collections.

Acknowledgements

This work was supported by the European Regional Development Fund through the Operational Programme "Science and Education for Smart Growth" under contract UNITE № BG05M2OP001-1.001-0004 (2018-2023).

References

- Burdea, G. (1996). *Force and touch feedback for virtual reality*. New York: Wiley Interscience.
- Cho, H.-C., Kim, B.-S., Park, J.-J., & Song, J.-B. (2006). Development of a Braille Display using Piezoelectric Linear Motors. *SICE-ICASE International Joint Conference*. Bexco, Busan, Korea.
- Friskin-Gibson, S. F., Bach-Y-Rita, P., Tompkins, W., & J.G., W. (1987). A 64-Solenoid, Four-Level Fingertip Search Display For The Blind. *Ieee Transactions On Biomedical Engineering, Bme-34*.
- Garrod, B., & Fyall, A. (2000). Managing Heritage Tourism. *Annals of Tourism Research(27(3))*, 682-708.
- Genkov, D. (2011). An Approach for Finding Proper Packet Size in IPv6. *CompSysTech'11*. Vienna, Austria.
- Simeonov, S., & Simeonova, N. (2013). Graphical Interface for Visually Impaired People Based on Bi-stable Solenoids. *The Proceeding of International Conference on Soft Computing and Software Engineering 2013 [SCSE'13],, Vol. 3, No. 3*, pp. 844-847. San Francisco, CA, U.S.A. doi:10.7321/jscse.v3.n3.128
- Valič, U. (2015). *ACCESSIBILITY of cultural heritage to vulnerable groups : study on the availability and provision of technical conditions to provide vulnerable groups with access to cultural heritage* . Ljubljana: Slovene Ethnographic Museum.

- Wu, X., Zhu, H., Kim, S., & Allen, M. G. (2007). A portable pneumatically-actuated refreshable braille cell. *The 14th International Conference on Solid-State Sensors, Actuators and Microsystems*. Lyon, France.
- Yang, G.-H., Kyung, K.-U., Srinivasan, M., & Kwon, D.-S. (2006). Quantitative Tactile Display Device with Pin-Array Type Tactile Feedback and Thermal Feedback. *Proceedings of the 2006 IEEE International Conference on Robotics and Automation*. Orlando, Florida.
- Yobas, L., Durand, D. M., Skebe, G. G., Lisy, F. J., & Huff. (2003, June 3). A Novel Integrable Microvalve for Refreshable Braille Display System. *Journal of microelectromechanical systems*, 252-263.

Received: June 30, 2019

Reviewed: July 10, 2019

Finally Accepted: July 22, 2019